

Analysis of Supporting Tool Application Testing Generator Excitation System at Steam Power Plant

Arnawan Hasibuan^{1*}, Rizky Almunadiansyah², Muhammad Daud³, Fahrian Roid⁴,
Kerimzade G.S⁵

^{1,2,3,4}Electrical Engineering Department, Universitas Malikussaleh, Lhokseumawe 24355, Indonesia

⁵Candidate of Technical Sciences, Associate Professor of the Department of Electromechanics of the Azerbaijan State Oil and Industry University, Azadliq prospekt 34, Baku, Az1010, Azerbaijan

Article Info

Article history:

Received March 20, 2025

Revised March 26, 2025

Accepted March 30, 2025

Keywords:

Excitation System Testing;
Supporting Tool;
Generator Excitation;
Generator;

ABSTRACT

This research aims to explore a preventive method to reduce damage to the excitation system during the startup phase of a Steam Power Plant using an Automatic Voltage Regulator (AVR). The primary objective is to enhance the efficiency and effectiveness of repair and maintenance procedures for the excitation system. A descriptive qualitative approach was employed, focusing on a generator in the steam power plant production area. The study involved defining the problem, engaging in discussions with the maintenance team, designing and testing the AVR, prioritizing the use of supporting tools during outages, and analyzing the outcomes. These processes helped identify and resolve underlying issues in the system. The study revealed a significant improvement in maintenance procedures. Previously, the average repair time for the excitation system was 8 hours, occurring approximately 10 times per year. After implementing the supporting tool and conducting tests while the unit was offline, the verification process was reduced to only 20 minutes. As a result, no damage occurred to excitation system components during gradual startup. This improvement leads to substantial cost savings—approximately IDR 4 billion—through reduced fuel consumption and more efficient use of electrical energy.

This is an open access article under the [CC BY-SA](https://creativecommons.org/licenses/by-sa/4.0/) license.



Copyright © 2025 Author(s)

Journal

All rights reserved

DOI: <https://doi.org/10.63935/akiratech.v2i1.110>

Corresponding Author:

Arnawan Hasibuan,

JL. Teungku Chie Ditiro, No. 26 Lantai 3, Kampus Unimal Lancang Garam Kota Lhokseumawe 24351, Aceh Indonesia

Email: arnawan@unimal.ac.id

1. INTRODUCTION

Damage to the excitation system is one of the issues in generators that requires a long repair time and significantly affects the continuity of power plant operations. The excitation system plays a vital role in regulating terminal voltage and maintaining system stability. However, failures in this system often go undetected in the early stages because its optimal performance can only be assessed during the rolling process leading to the synchronization phase [1]–[3].

A common problem found is the failure of internal components in the excitation system, which, if not addressed immediately, can cause major disruptions to the overall power generation system [4]. Repair work carried out during the firing phase is highly disruptive, resulting in power losses, wasted time, and continuous diesel fuel consumption [5]–[7]. Therefore, a method is needed to minimize the risk of excitation system failure before the generating unit enters full operation.

This research is driven by the urgency to reduce critical failures in the excitation system by conducting early testing and analysis of its components before the Steam Power Plant enters the firing stage. In this regard, a specially designed supporting tool is used to identify the performance of each excitation system component at an early stage [8]. This enables fault detection before the system is operated, allowing for quicker response and resolution times.

By conducting early testing using the supporting tool, the firing process is expected to be more efficient. Furthermore, the optimization of the excitation system will result in reduced self-consumption power, time efficiency, and coal fuel savings during the firing process [9]. This study makes an important contribution to the development of predictive maintenance strategies in steam power generation systems.

2. METHOD

The excitation system is a DC power supply system as an amplifier for an electric generator or as a magnetic field generator, so that a generator can produce electrical energy with a generator output voltage depending on the magnitude of the excitation current [10], [11]. The excitation system is equipped with an AVR (Automatic Voltage Regulator) which works based on the increase and decrease in load read by PT (Potential Transformer) and CT (Current Transformer) as illustrated in Figure 1 below.

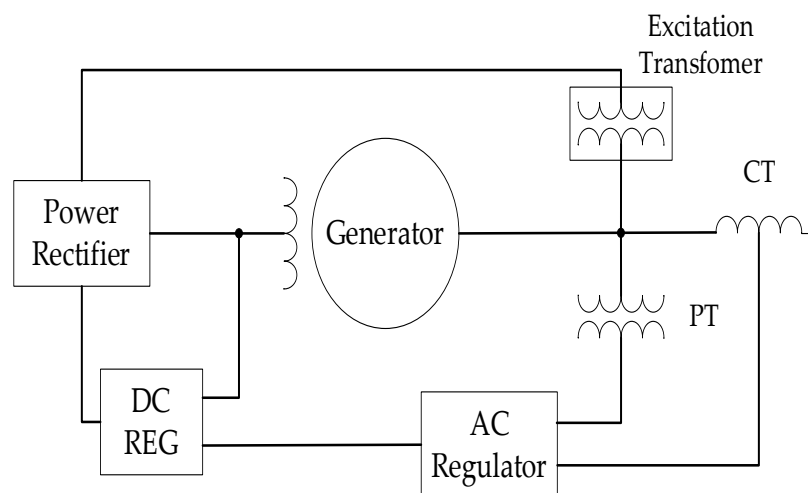

Figure 1. Generator Excitation System with Carbon Brush.

2.1. Supporting Tools

AVR (Auto Voltage Regulator) serves to prevent damage or interference to the generator excitation system when the unit starts up [12]. The working principle is that when the 380 V AC voltage is supplied to the 3-phase transformer regulator, it is lowered to 25 V AC so that it is sent to the secondary PT (Potential Transformer) generator and is rectified to a DC voltage through the thyristor. If a voltage of 25 V AC enters the excitation system, channel A, channel B and channel C will read a simulated generator voltage of 3136 V AC (3.136 KV AC), and at the thyristor output a DC voltage of 14.47 V DC will be output on channel A and channel B (automatic voltage regulation). Whereas on channel C the thyristor output voltage is 0 V (manual voltage setting). In this system, the DC voltage is sent to the 6 KW heater (replacing the generator rotor). If the sinusoidal wave moves without breaking, then the thyristor is working normally and if it moves interrupted, it is necessary to check the 12 thyristors. This tool is applied when the unit is outage, so as to know the performance of the excitation system without waiting for firing. The shape of the AVR from various sides can be seen in Figure 2 below.

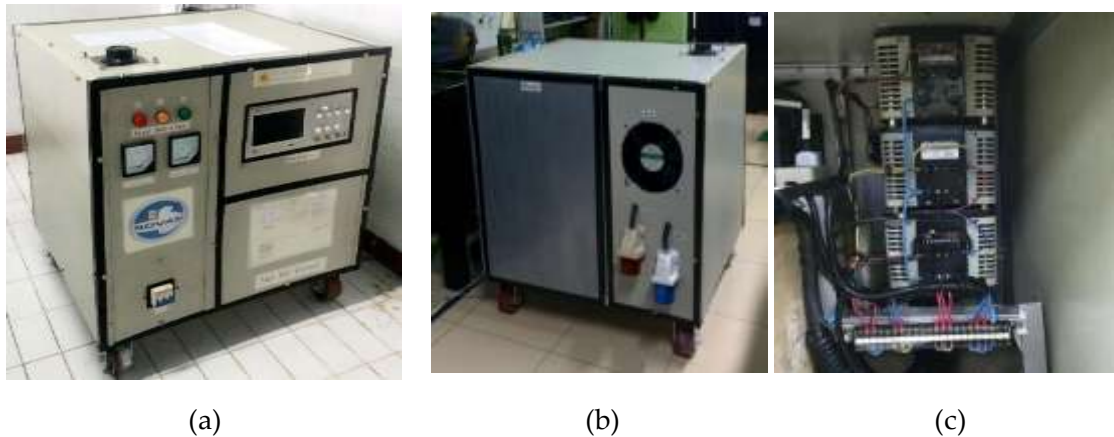

Figure 2. Excitation System Testing Support Tools (a) front view, (b) back view, (c) installation view

This study uses descriptive qualitative methods, namely observation and observation of an object and describe it. This research is in the form of generator excitation system data at the Steam Power Plant Labuhan Angin generator unit.

3. RESULTS AND DISCUSSION

Generator damage that often occurs at the Labuhan Angin Steam Power Plant is damage to the excitation system, which occurs when the unit is starting up (firing) for synchronization. The damage makes a lot of losses when identifying repairs, and the supply of AC output power produced by the generator is disrupted. The actual losses that occur when repairing the excitation component are fuel consumption, electrical power and ineffective repairs when the unit starts up.

Repairing excitation components is time-consuming, because component checks are carried out carefully, sequentially and carefully and the material is very sensitive to heat and voltage so that if the repair is not appropriate it will take outage time per year and the unit's operating performance target is not achieved [13]. On the other hand, the outage time available until synchronization to the system is not much. The appearance of thyristor damage in the excitation system is shown in Figure 3.



Figure 3. Damage to the Thyristor in the Excitation System

When repairing the excitation system at the synchronization stage takes an average of 8 hours for minor component damage. If the damage is major and needs replacement it will take 48 hours. There needs to be a supporting tool that can simplify and shorten the time in identifying maintenance. Of course, supporting is in the safe category for the human team, and for components without reducing the original nature of these components. In fact, what affected the completion time of maintenance identification were the tools that were not available when repairing the excitation system before firing. In addition, there is a settlement method that is less effective because identification and repair are carried out when the unit is firing. This problem will be overcome in order to achieve maintenance that is fast, precise, and effective.

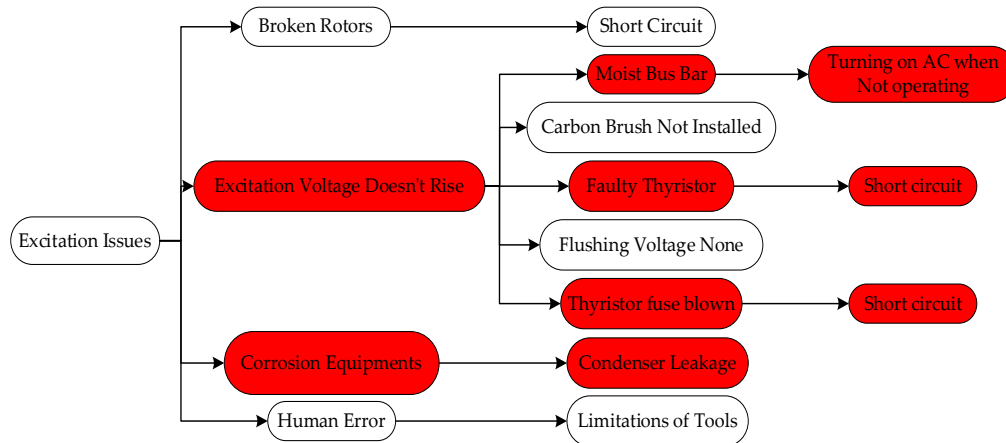

Figure 4. Possible causes of excitation burnout

With Excitation System Testing Support, if there is damage to the excitation part it will not take a long time to repair. This tool is implemented offline or when the unit is out of service. So you can find out the performance of the excitation system without waiting for firing, which in fact conventionally excitation testing is carried out while the unit is firing.

4. CONCLUSION

Based on the results of the discussion in the study, several conclusions were obtained, namely: The duration of the firing time becomes even faster, because there will be no damage to the excitation system after the implementation of the supporting tool. In this implementation, the difference in the duration of 8 hours per repair (before the implementation of the supporting tool) is quite productive time to produce electric power which is sold, with an average annual rate from 2015 to 2016 of 10 times, so that PLN can save 4.1 billion rupiah per year per unit. Critical components of the excitation system such as thyristors, relays, triggers, etc. are safer and the material is well maintained, because they will not be damaged during firing which takes a lot of time if damaged during synchronization. Because it has been tested and repaired beforehand when the unit is outage.

REFERENCES

- [1] H. Saadat, *Power System Analysis*, 3rd ed., New York, NY, USA: McGraw-Hill, 2010.
- [2] P. Kundur, *Power System Stability and Control*, New York, NY, USA: McGraw-Hill, 1994.
- [3] IEEE Power and Energy Society, "IEEE Guide for Synchronous Generator Modeling Practices and Applications in Power System Stability Analyses," *IEEE Std 1110-2019*, 2019.
- [4] A. El-Hady, M. M. Mansour, and H. S. Ramadan, "Reliability evaluation of excitation systems in synchronous generators," *Electric Power Systems Research*, vol. 148, pp. 1–10, Jul. 2017.
- [5] M. El-Hawary, *Electric Power System Design and Analysis*, New York, NY, USA: CRC Press, 2013.
- [6] R. C. Dugan, M. F. McGranaghan, S. Santoso, and H. W. Beaty, *Electrical Power Systems Quality*, 3rd ed., New York, NY, USA: McGraw-Hill, 2012.
- [7] I. J. Nagrath and D. P. Kothari, *Power System Engineering*, 2nd ed., New Delhi, India: Tata McGraw-Hill, 2008.
- [8] J. Machowski, J. W. Bialek, and J. R. Bumby, *Power System Dynamics: Stability and Control*, 2nd ed., Chichester, UK: Wiley, 2008.
- [9] S. B. Dewi, A. H. Pramono, and A. S. Wijayanto, "Performance evaluation of excitation system using supporting tools at power plant," *Journal of Electrical Systems*, vol. 16, no. 4, pp. 567–575, Dec. 2020.
- [10] L. J. Powell, "The impact of system grounding practices on generator fault damage," *IEEE Trans. Ind. Appl.*, vol. 34, no. 5, pp. 923–927, 1998.
- [11] M. Farhan, "Pengaruh Pembebanan Terhadap Arus Eksitasi Generator Unit 2 PLTMH Curug," *J. Simetrik*, vol. 11, no. 1, pp. 398–403, 2021.
- [12] T. M. Jahns, G. B. Kliman, and T. W. Neumann, "Interior permanent-magnet synchronous motors for adjustable-speed drives," *IEEE Trans. Ind. Appl.*, no. 4, pp. 738–747, 1986.
- [13] S. A. Rao, K. P. Rao, and P. Anil, "Operational Problems in turbo generators and their analysis," *Water Energy Int.*, vol. 61, no. 2, pp. 37–41, 2018.
- [14] R. C. Schaefer, "Application of static excitation systems for rotating exciter replacement," in *Conference Record of 1997 Annual Pulp and Paper Industry Technical Conference*, 1997, pp. 199–208.
- [15] A. Hasibuan, M. Isa, M. I. Yusoff, S. R. A. Rahim, and I. Nrartha, "Effect of installation of distributed generation at different points in the distribution system on voltage drops and power losses," in *AIP Conference Proceedings*, 2021.
- [16] A. Hasibuan, S. Masri, and W. Othman, "Effect of distributed generation installation on power loss using genetic

- algorithm method,” in *IOP Conference Series: Materials Science and Engineering*, 2018, p. 12034.
- [17] H. Abbas, J. Jamaluddin, M. Arif, and A. Amiruddin, “Analisa Pembangkit Tenaga Listrik Dengan Tenaga Uap Di Pltu,” *ILTEK J. Teknol.*, vol. 14, no. 01, pp. 2024–2028, 2019, doi: 10.47398/iltek.v14i01.362.
- [18] H. Arnawan, I. Muzamir, I. Y. Mohd, R. A. R. Siti, and S. Hadi, “Evaluation of 20 kV Distribution Network Losses In Radial Distribution Systems Due to Distributed Generation Penetration,” in *Journal of Physics: Conference Series*, 2021, p. 12085.
- [19] I. C. Report, “Excitation system models for power system stability studies,” *IEEE Trans. power Appar. Syst.*, no. 2, pp. 494–509, 1981.
- [20] R. Rimbawati, P. Harahap, and K. U. Putra, “Analisis Pengaruh Perubahan Arus Eksitasi Terhadap Karakteristik Generator (Aplikasi Laboratorium Mesin-Mesin Listrik Fakultas Teknik-Umsu),” *RELE (Rekayasa Elektr. dan Energi) J. Tek. Elektro*, vol. 2, no. 1, pp. 37–44, 2019.