

Literature Survey of US Patents for Turbo Code

Mohanad Abdulhamid

¹ Al-hikma University, Iraq

Article Info

Article history:

Received March 11, 2026

Revised March 13, 2026

Accepted March 14, 2026

Keywords:

US Patents

Turbo code

structure and applications

ABSTRACT

Turbo codes are a class of high-performance forward error correction (FEC) codes used in information theory that were first published in 1993 but were developed between 1990 and 1991. They were the first working codes to get very close to the Shannon limit, also known as the maximum channel capacity, which is the highest theoretical code rate at which dependable communication is still feasible at a given noise level. In 3G/4G/5G mobile communications, turbo codes are utilized (e.g. in satellite communications, UMTS and LTE), and other applications where designers aim to accomplish dependable information transfer over communication links with limited bandwidth or latency in the presence of data-corrupting noise. In addition to outlining its structure, this paper offers a succinct explanation of how Turbo Code is used in US patents.

Copyright © 2026 Akiratech
 Journal

All rights reserved

DOI: <https://doi.org/10.63935/akiratech.v3i1.296>

Corresponding Author:

Mohanad Abdulhamid,

Al-hikma University, Iraq

Email: moh1hamid@yahoo.com

1. INTRODUCTION

Error-correcting codes play an essential role in modern digital communication systems by improving the reliability of data transmission over noisy communication channels. These coding techniques are designed to detect and correct errors that may occur during data transmission, thereby ensuring accurate information delivery. Among the many channel coding techniques developed in communication theory, turbo codes represent one of the most significant breakthroughs due to their ability to approach the Shannon limit with relatively low decoding complexity [1].

Turbo codes were first introduced in 1993 by Claude Berrou, Alain Glavieux, and Punya Thitimajshima in their seminal paper presented at the IEEE International Conference on Communications 1993. The concept of turbo coding was originally protected through patent applications submitted in 1991 in the United States [2]. The fundamental idea of turbo codes is based on the parallel concatenation of recursive systematic convolutional (RSC) encoders combined with an interleaver to generate powerful error correction capability. This innovative coding structure allows turbo codes to achieve performance very close to the theoretical Shannon limit [1].

Since their introduction, turbo codes have been widely adopted in various communication systems, including satellite communications, deep-space communications, and mobile communication systems. Due to their excellent error-correction performance, turbo codes have been implemented in several international communication standards such as 3G mobile systems and satellite communication protocols [3]. As a result, extensive research and technological developments have been conducted to improve turbo code performance, leading to numerous patents related to turbo coding techniques.

The large number of patents associated with turbo code technology reflects the continuous innovation and industrial interest in this field. Patent analysis can provide valuable insights into technological trends, major inventors, and the evolution of turbo coding techniques. However, despite the importance of turbo codes in modern communication systems, there has been limited research focusing on a systematic survey of patents related to this technology, particularly within the United States patent database.

Therefore, this study presents a literature survey of United States patents related to turbo code technology. The objective of this research is to analyze the development of turbo code patents, identify the

main contributors in this field, and explore technological trends associated with turbo coding techniques based on data obtained from the United States patent database.

2. Turbo Code Structure

2.1 Turbo Code encoder

Fig.1 displays the classic turbo code encoder. Three bits sub-blocks are sent by this encoder implementation. The m-bit payload data block is the first sub-block. The second sub-block, which uses a recursive systematic convolutional code (RSC code), contains n/2 parity bits for the payload data. The third sub-block, which is once more calculated using an RSC code, consists of n/2 parity bits for a known permutation of the payload data. As a result, the payload contains two redundant but distinct parity bit sub-blocks. With a code rate of $m/(m + n)$, the entire block contains $m + n$ bits of data. An interleaver is a device that performs the permutation of the payload data.

According to Fig.1, this turbo code encoder is made up of two identical RSC coders, C1 and C2, that are joined to one another by a concatenation technique known as parallel concatenation.

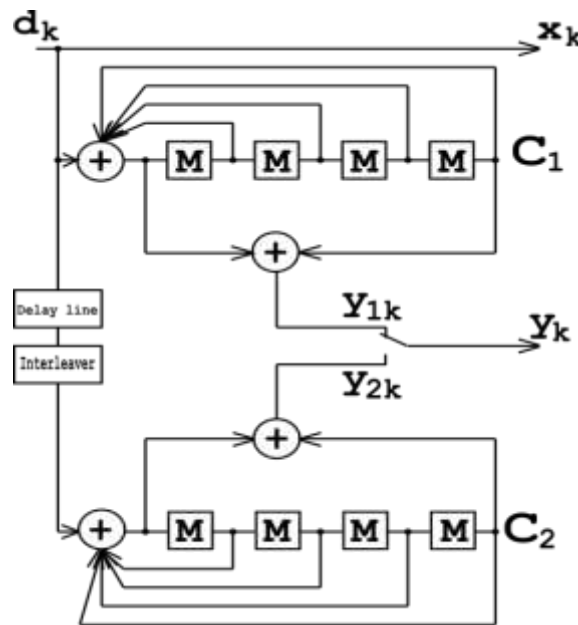

Fig.1 Turbo code encoder

2.2- Turbo Code Decoder

As illustrated in Fig. 2. The decoder is constructed similarly to the encoder mentioned above. There is a connection between two elementary decoders, but it is in series rather than parallel.

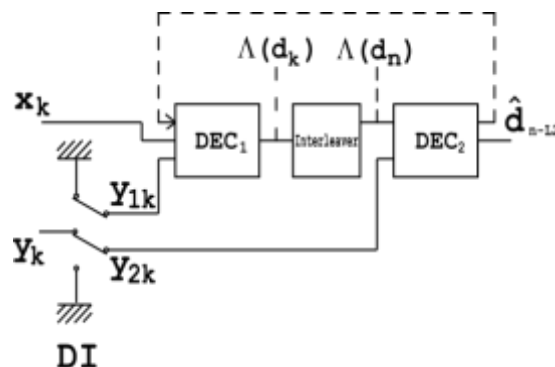

Fig.2 Turbo code decoder

2.2.1 Applications and advantages of turbo codes in military communications

Turbo codes are used in military communication systems due to their ability to achieve reliable data transmission in challenging, noisy environments, which is crucial for secure and effective communication

between military personnel and assets. They offer significant advantages in terms of power reduction, interference handling, and error correction capabilities.

2.3 Key Advantages of Turbo Codes in Military Communication

2.3.1- Power Reduction

Turbo codes allow for a reduction in transmitted power while maintaining reliable communication. This is vital in military applications where minimizing signal detection is crucial, and power conservation can be critical for the longevity of battery-powered devices.

2.3.2- Improved Interference Handling

Turbo codes are designed to handle interference and jamming more effectively than traditional coding techniques. This is essential in military operations where adversaries may attempt to disrupt communications.

2.3.3- Error Correction

Turbo codes excel at error correction, ensuring that messages are received with minimal errors, even in noisy channels. This reliability is paramount in critical military communications where accurate information is essential.

3. METHOD

3.1 Research Design

Penelitian ini menggunakan pendekatan systematic patent survey untuk menganalisis perkembangan teknologi turbo code berdasarkan dokumen paten yang terdaftar di Amerika Serikat. Metode ini bertujuan untuk mengidentifikasi tren inovasi, kontribusi inventor, serta perkembangan teknologi turbo code melalui analisis data paten yang tersedia pada database paten.

Patent analysis merupakan metode yang banyak digunakan dalam studi perkembangan teknologi karena dokumen paten berisi informasi teknis yang detail serta menggambarkan arah inovasi suatu bidang teknologi.

3.2 Data Source

Data paten dalam penelitian ini diperoleh dari basis data paten resmi Amerika Serikat yaitu:

- United States Patent and Trademark Office (USPTO)
- Google Patents

Kedua basis data tersebut menyediakan akses terbuka terhadap dokumen paten yang dapat digunakan untuk analisis teknologi dan inovasi.

3.3 Patent Search Strategy

Proses pencarian paten dilakukan menggunakan beberapa kata kunci yang berkaitan dengan teknologi turbo code, antara lain:

- “turbo code”
- “turbo coding”
- “turbo encoder”
- “turbo decoder”

Pencarian dilakukan pada judul, abstrak, dan klaim paten untuk memastikan bahwa dokumen yang diperoleh benar-benar berkaitan dengan teknologi turbo code.

Selain itu, pencarian juga difilter berdasarkan klasifikasi teknologi komunikasi digital yang termasuk dalam International Patent Classification (IPC) kategori sistem komunikasi digital.

3.4 Data Selection Criteria

Setelah proses pencarian dilakukan, dokumen paten yang diperoleh kemudian diseleksi berdasarkan beberapa kriteria berikut:

Inclusion Criteria

- Paten yang secara langsung membahas teknologi turbo code
- Paten yang terdaftar di Amerika Serikat
- Paten yang berhubungan dengan encoder, decoder, interleaver, atau sistem komunikasi berbasis turbo code

Exclusion Criteria

- Paten yang hanya menyebut turbo code secara umum tanpa kontribusi teknis
- Dokumen duplikasi atau paten yang tidak relevan dengan topik penelitian

3.5 Data Analysis Method

Analisis data paten dilakukan menggunakan metode descriptive patent analysis untuk mengidentifikasi beberapa aspek utama perkembangan teknologi turbo code, yaitu:

1. Distribusi paten berdasarkan tahun publikasi untuk melihat perkembangan teknologi dari waktu ke waktu.
2. Distribusi paten berdasarkan inventor dan institusi untuk mengetahui pihak yang paling aktif dalam pengembangan teknologi turbo code.
3. Klasifikasi teknologi paten untuk mengidentifikasi bidang inovasi yang paling dominan dalam teknologi turbo code.
4. Analisis tren teknologi untuk melihat arah perkembangan riset dan inovasi turbo code di masa depan.

Hasil analisis kemudian disajikan dalam bentuk grafik, tabel, dan deskripsi analitis untuk memberikan gambaran yang jelas mengenai perkembangan paten turbo code di Amerika Serikat.

4. RESULTS AND DISCUSSION

4.1 Applications of turbo codes in US Patents

The analysis of United States patents reveals that turbo code technology has been widely applied in various communication and signal processing systems. These applications mainly focus on improving decoding performance, enhancing error correction capability, and increasing communication reliability in complex transmission environments.

One important category of patents focuses on improving turbo code decoding algorithms. For example, the patent described in [2] proposes a decoding method that combines a turbo code generator matrix with a cyclic redundancy check (CRC) generator matrix. The decoding process utilizes a log-likelihood ratio sequence obtained from the turbo decoder and performs CRC-assisted iterative ordered statistics decoding. This approach improves the decoding performance and enhances the reliability of turbo-coded communication systems.

Another application of turbo codes can be found in digital television broadcasting systems. The patent in [3] introduces a method for transmitting turbo-coded data in digital television systems using coded orthogonal frequency division multiplexing (COFDM) combined with quadrature amplitude modulation (QAM). In this system, parity bits are mapped in QAM constellations in a way that enables more reliable demapping compared to conventional methods. This design simplifies turbo decoding and improves signal reception in broadcast environments.

Several patents also focus on advanced communication system performance prediction and receiver design. The invention described in [4] proposes a communication system capable of predicting performance over transmission channels using turbo-coded bit-interleaved coded modulation. The receiver employs an iterative interference cancellation technique that includes an equalizer, demodulator, and turbo decoder. Such iterative processing significantly improves decoding accuracy and system performance in noisy communication channels.

Turbo codes are also widely used in broadcast signal processing systems. The patent presented in [5] describes a receiving system that includes a tuner, channel equalizer, turbo decoder, demultiplexer, and additional error correction modules. In this system, turbo decoding is applied to signaling data contained in broadcast signals before further processing steps such as block deinterleaving and additional error correction are performed.

Another important research direction involves reducing the error floor of turbo-like codes. The patent described in [6] proposes an enhanced decoding technique that identifies bits most affected by transmission errors and modifies their likelihood values in order to improve decoder convergence. This method significantly reduces the error floor of turbo codes while maintaining spectral efficiency.

Turbo coding has also been applied in wireless communication systems. The invention in [7] introduces a data transmission method in which a base station sends control signaling to a terminal device to indicate the coding method used for a service channel. This mechanism enables flexible selection of coding techniques, including turbo codes, depending on system requirements.

Another patent related to wireless systems is described in [8], which proposes a turbo-demodulation scheme that combines an iterative MIMO decoder with an iterative channel decoder. The system performs multiple decoding iterations to improve symbol detection and enhance overall system performance.

Dynamic channel coding configuration is another application area of turbo codes. The patent described in [9] proposes a wireless communication system capable of switching between different channel coding configurations according to system requirements. This flexible coding scheme allows the system to maintain efficient communication performance under varying transmission conditions.

More recent developments include the use of machine learning techniques to improve turbo decoding performance. The patent presented in [10] describes a system that trains a classifier to predict the decoding outcome of codewords. Based on this prediction, the system can adjust decoder parameters to improve decoding efficiency and performance.

In addition, turbo codes have been applied in signal generation and encoding techniques, as described in [11]. The proposed approach employs multiple encoders and interleaving processes to generate redundancy symbols that improve the robustness of transmitted information.

Further innovations involve advanced encoding techniques for data transmission. The patent described in [12] proposes a system that generates feature probability distributions for source data and encodes them using a distribution channel encoder implemented through a polarization stream network.

Turbo codes have also been used in biological data decoding systems. The method described in [13] applies soft decoding algorithms with error correction codes to decode DNA nucleotide sequences obtained from nanopore sequencing measurements. This demonstrates that turbo coding techniques can also be applied in bioinformatics and data analysis applications.

Another application area involves forward error correction for wireless transmission systems. The patent in [14] describes a turbo-code-based encoding technique for segmenting transport blocks and determining encoding parameters to achieve the desired code rate in wireless communication systems.

Finally, turbo codes have also been used in non-binary error-correcting coding systems, as described in [15]. The proposed transmission method utilizes pseudo-random sequences and modulation techniques to transmit non-binary codewords efficiently over communication channels.

Overall, the analysis of these patents indicates that turbo codes have been widely applied across various technological domains, including digital broadcasting, wireless communications, signal processing, and even bioinformatics. Most of the innovations focus on improving decoding performance, reducing transmission errors, and enhancing communication reliability in complex transmission environments.

5. CONCLUSION

This study presented a literature survey of United States patents related to turbo code technology. The results show that turbo codes remain an important component of modern communication systems due to their excellent error correction capability and ability to approach the Shannon limit.

The analysis of recent patents indicates that research and innovation in turbo coding mainly focus on improving decoding algorithms, enhancing communication reliability, and integrating turbo codes with advanced communication technologies such as wireless communication systems, digital broadcasting systems, and iterative signal processing techniques.

Furthermore, the study highlights the fundamental structure of turbo codes, including the use of parallel concatenated convolutional encoders and iterative decoding mechanisms. The findings of this survey provide an overview of the technological development and applications of turbo codes in recent years and may serve as a useful reference for future research in channel coding and communication systems.

ACKNOWLEDGEMENTS

The authors would like to thank all individuals and institutions that provided support and valuable assistance during the completion of this research. Their encouragement and constructive contributions were greatly appreciated.

REFERENCES

- [1] C. Berrou, A. Glavieux, and P. Thitimajshima, "Near Shannon limit error-correcting coding and decoding: Turbo-codes," in *Proceedings of the IEEE International Conference on Communications (ICC)*, Geneva, Switzerland, May 1993, pp. 1064–1070, doi: **10.1109/ICC.1993.397441**.
- [2] C. Berrou, "Error-correction coding method and device," U.S. Patent **5,446,747**, Aug. 29, 1995.
- [3] T. K. Moon, *Error Correction Coding: Mathematical Methods and Algorithms*. Hoboken, NJ, USA: Wiley, 2005, doi: **10.1002/047174882X**.
- [4] B. Claude, "Near Shannon Limit Error – Correcting", *Proceedings of IEEE International Communications Conference*, vol. 2, pp. 1064–70, 1993.
- [5] Xiong; Jie et al., "Method and decoder for processing decoding ", US-20150006992A1, 2015.
- [6] L. Allen, "COFDM broadcast systems employing turbo coding", US-9143785B2, 2015.
- [7] S. Gyu et al., "Transmitting/receiving system and method of processing broadcast signal in transmitting/receiving system", US-RE45834E, 2016.

- [8] G. Benjamin et al., "Method of decoding a correcting code, for example a turbo-code, by analysis of the extended spectrum of the words of the code", US-9391644B2, 2016.
- [9] S. Robert et al., "Apparatus and method for non-orthogonal transmissions", US-20180123636A1, 2018.
- [10] C. Jun et al., "Data transmission method, base station, and terminal device", US-20180206221A1, 2018.
- [11] C. Damien, "Method and device and computer program for demodulating received symbols using turbo-demodulation scheme", US-10454502B2, 2019.
- [12] N. Kwangseok et al., "Method for channel coding in wireless communication system and apparatus therefor", US-10707990B2, 2020.
- [13] Z. Ran et al., "Iterative decoder performance prediction using machine learning", US-11088712B2, 2021.
- [14] K. Rami et al., "Method for generating a signal by means of a turbo-encoder, and corresponding device and computer program", US-20220060198A1, 2022.
- [15] G. Yiqun et al., "Encoding and decoding source information using a distribution channel encoder and decoder", US-Encoding and decoding source information using a distribution channel encoder and decoderB2, 2022.
- [16] C. Laura, "Method and device for decoding data stored in a DNA-based storage system", US-20230187024A1, 2023.
- [17] R. Chul et al., "Code block segmentation and configuration for concatenated turbo and RS coding", US-20240113804A1, 2024.
- [18] S. Valentin et al., "Methods and devices for transmitting and receiving non-binary error correcting code words", US-12273200B2, 2025.